

#### ■ 技术参数 TECHNICAL PARAMETR

1. 间距 Pitch: 1.00mm
2. 极数 Poles: 30
3. 额定电流 Current Rating: 1.0A AC/DC.
4. 额定电压 Voltage Rating: 210V AC/DC.
5. 温度范围 Temperature range: -25°C~+85°C
6. 耐压 Withstand Voltage: 500V/min
7. 接触电阻 Contact resistance:  $\leq 40\text{m}\Omega$
8. 绝缘电阻 Insulation resistance:  $\geq 100\text{M}\Omega$
9. 适用电线 Applicable wire: AWG#36~#28

#### ■ A1003T (Crimp Terminal)

##### Reference Infomations:

\*Used in CG A1003 series Housing

\*Tolerance:(unit:mm).0 ±0.30/.0 ±0.20/.0 ±0.10/±3.0°C

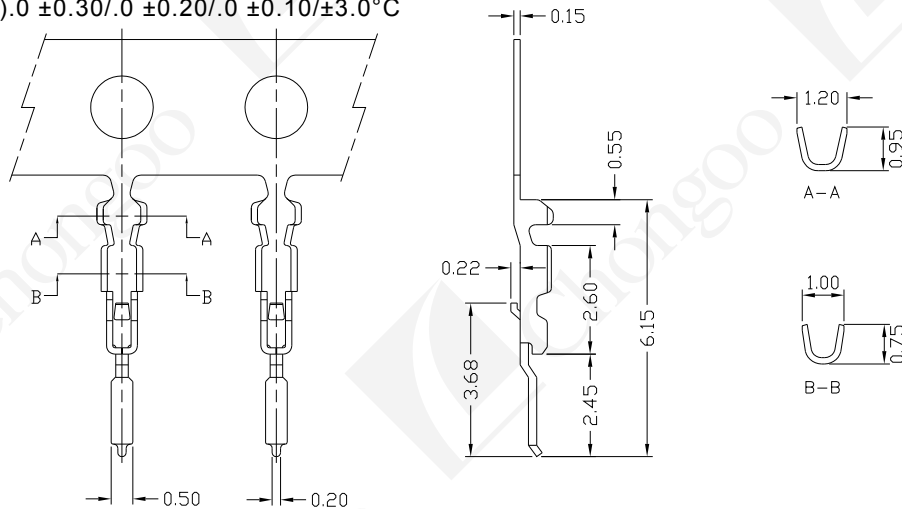

Part No	Wire Range	Insulation O.D.	Material	Finish	Qty/Reel
A1003T-PC-Z	AWG #28~#36	0.50mm(max)	Phosphor bronze	Gold-plated	

#### ■ A1003Y-30P (Housing)

##### Reference Infomations:

\*Material: Shell: Copper ally/Tin-plated

Wafer: PA46(UL94V-0)

\*Suitable CG A1003T series Terminal

\*Mates With CG A1001 Series Dual Row Housing

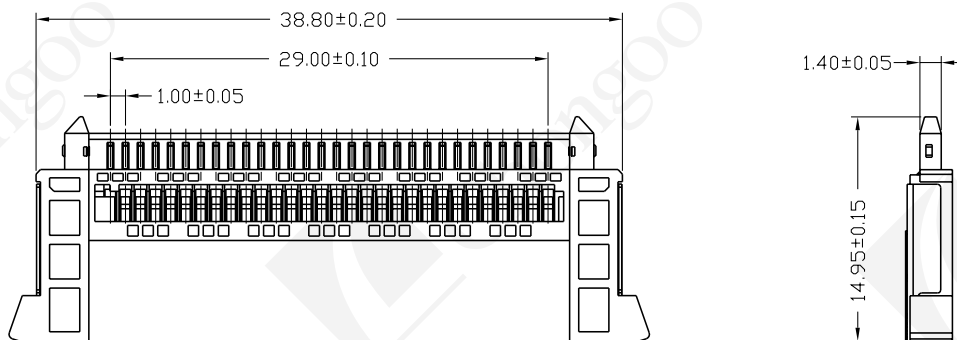
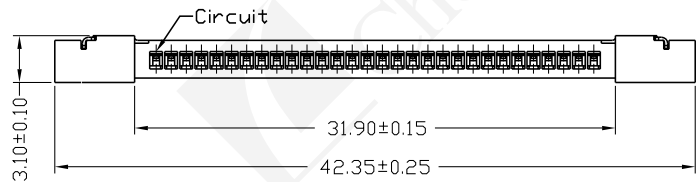

Wire to Board Connector