

■ 技术参数 TECHNICAL PARAMETR

1. 间距 Pitch: 2.00mm
2. 额定电流 Current Rating: 3.0A AC/DC.
3. 额定电压 Voltage Rating: 250V AC/DC.
4. 温度范围 Temperature range: -25°C~+85°C
5. 耐压 Withstand Voltage: 800V/min
6. 接触电阻 Contact resistance: $\leq 100\text{m}\Omega$
7. 绝缘电阻 Insulation resistance: $\geq 1000\text{M}\Omega$
8. 适用电线 Applicable wire: AWG#28~#24
9. 适应基板厚度 Applicable PC board thickness: 1.60mm

■ 安装图 Assembly layout

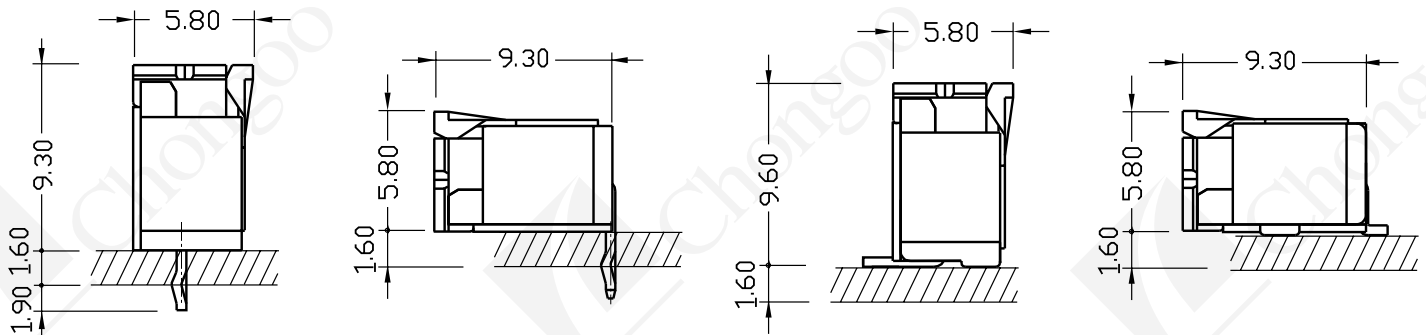

■ A2005T (Crimp Terminal)

Reference Infolmations:

*Used in CG A2005 Series Housing

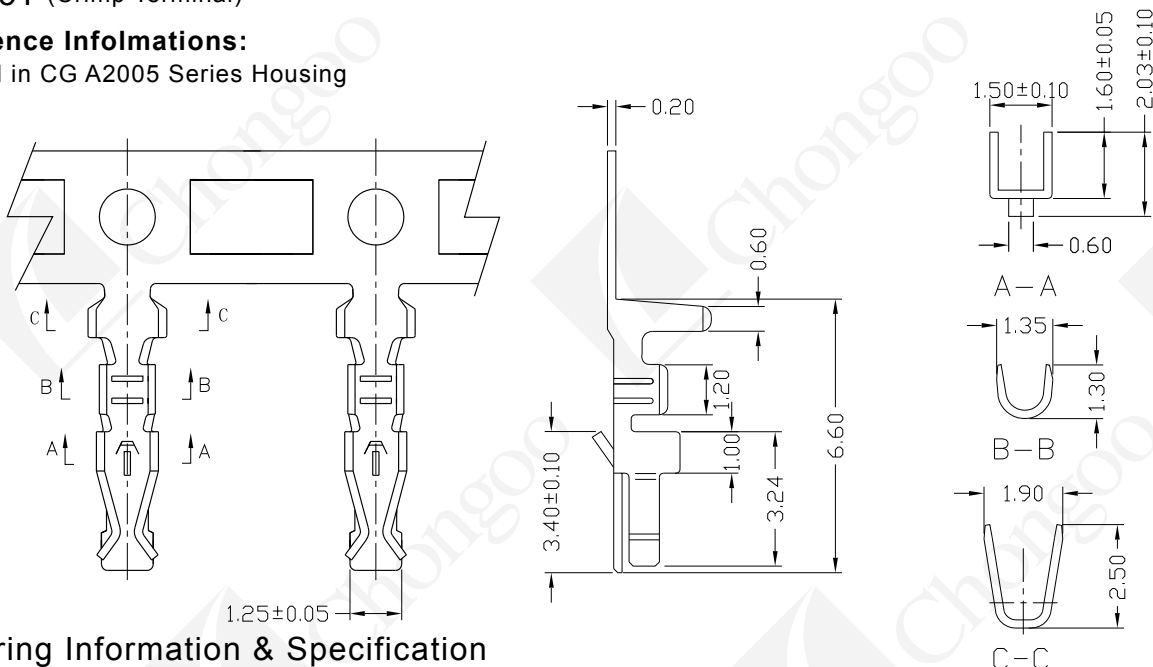

■ Ordering Information & Specification

Part No	Wire Range	Insulation O.D.	Material	Finish	Qty/Reel
A2005-PC-Z	AWG #28~#24	1.60mm(max)	Phosphor bronze	Gold-plated	

Unit:mm



■ A2005Y (Housing-Lock)

Reference Informations:

*Material:PA66 (UL94V-0)

*Suitable CG A2005 series Terminal

*Mates With CG A2005 Series Wafer

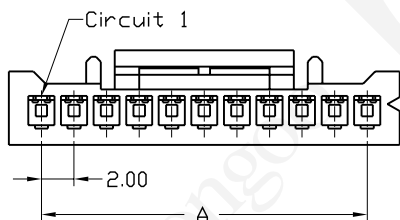
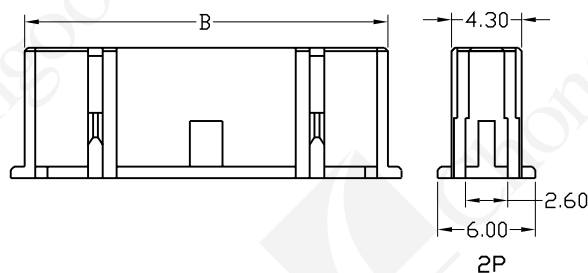
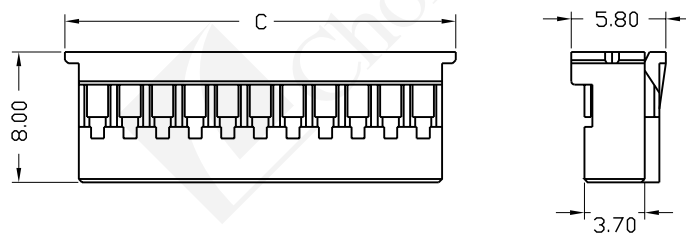
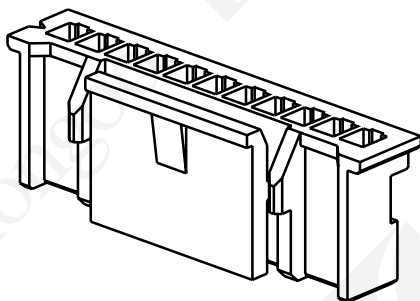

■ Ordering Informftion & Dimensions

PART No.	A	C	D	PART No.	A	C	D
A2005Y-2P	2.00	4.60	6.00	A2005Y-9P	16.00	18.60	20.00
A2005Y-3P	4.00	6.60	8.00	A2005Y-10P	18.00	20.60	22.00
A2005Y-4P	6.00	8.60	10.00	A2005Y-11P	20.00	22.60	24.00
A2005Y-5P	8.00	10.60	12.00	A2005Y-12P	22.00	24.60	26.00
A2005Y-6P	10.00	12.60	14.00	A2005Y-13P	24.00	26.60	28.00
A2005Y-7P	12.00	14.60	16.00	A2005Y-14P	26.00	28.60	30.00
A2005Y-8P	14.00	16.60	18.00	A2005Y-15P	28.00	30.60	32.00

■ A2005A (Vertical Angle Wafer DIP)

Reference Informations:

*Material:Pin:Brass /Tin-plated

Wafer:PA66 (UL94V-0)

*Mates With CG A2005 Series Housing

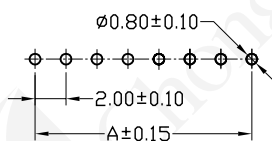
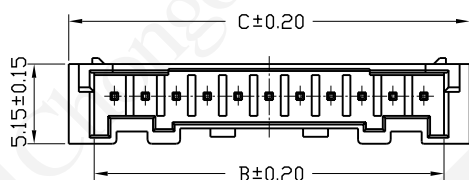
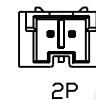
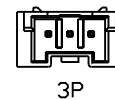
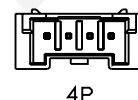
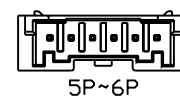
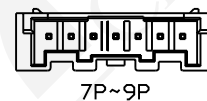
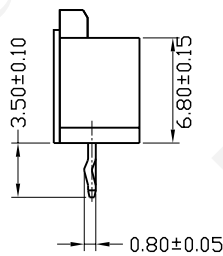
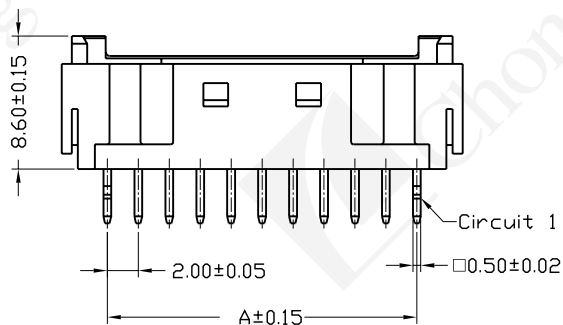
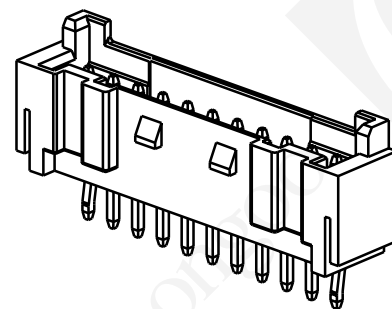

P.C.B Layout

■ Ordering Informftion & Dimensions

PART No.	A	C	D	PART No.	A	C	D
A2005A-2P	2.00	4.60	7.90	A2005A-9P	16.00	18.60	21.90
A2005A-3P	4.00	6.60	9.90	A2005A-10P	18.00	20.60	23.90
A2005A-4P	6.00	8.60	11.90	A2005A-11P	20.00	22.60	25.90
A2005A-5P	8.00	10.60	13.90	A2005A-12P	22.00	24.60	27.90
A2005A-6P	10.00	12.60	15.90	A2005A-13P	24.00	26.60	29.90
A2005A-7P	12.00	14.60	17.90	A2005A-14P	26.00	28.60	31.90
A2005A-8P	14.00	16.60	19.90	A2005A-15P	28.00	30.60	33.90

Wire to Board Connector

Unit:mm



■ A2005AW (Right Angle Wafer DIP)

Reference Informations:

*Material: Pin: Brass / Tin-plated

Wafer: PA66 (UL94V-0)

*Mates With CG A2005 Series Housing

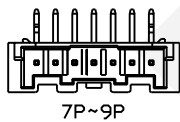
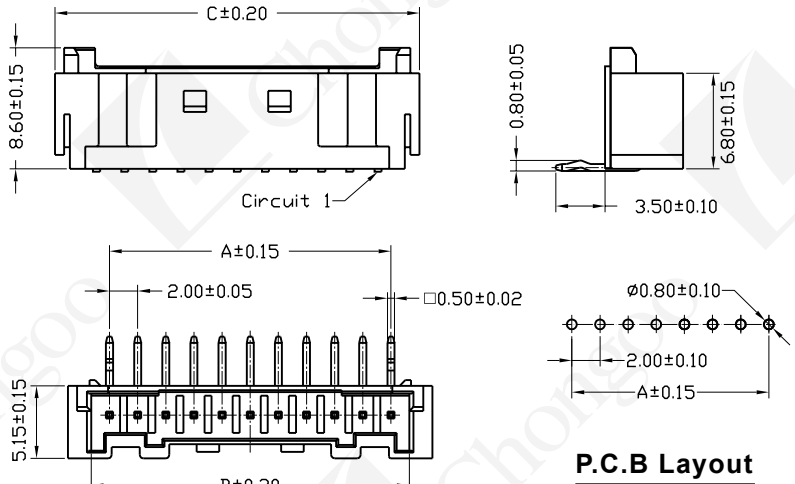
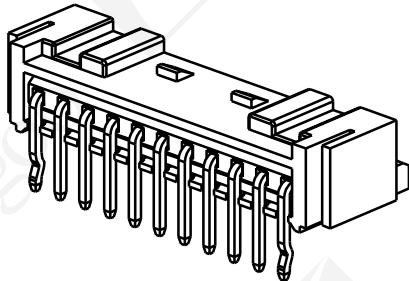

7P~9P

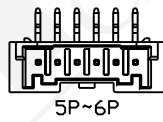

5P~6P

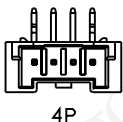

4P

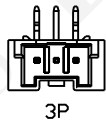

3P

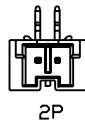

2P

■ Ordering Information & Dimensions

PART No.	A	C	D	PART No.	A	C	D
A2005AW-2P	2.00	4.60	7.90	A2005AW-9P	16.00	18.60	21.90
A2005AW-3P	4.00	6.60	9.90	A2005AW-10P	18.00	20.60	23.90
A2005AW-4P	6.00	8.60	11.90	A2005AW-11P	20.00	22.60	25.90
A2005AW-5P	8.00	10.60	13.90	A2005AW-12P	22.00	24.60	27.90
A2005AW-6P	10.00	12.60	15.90	A2005AW-13P	24.00	26.60	29.90
A2005AW-7P	12.00	14.60	17.90	A2005AW-14P	26.00	28.60	31.90
A2005AW-8P	14.00	16.60	19.90	A2005AW-15P	28.00	30.60	33.90

■ A2005AWV (Vertical Angle Wafer SMT)

Reference Informations:

*Material: Pin: Brass / Tin-plated

Solder Tabs: Phosphor Bronze / Tin-plated

Wafer: PA66 (UL94V-0)

*Mates With CG A2005 Series Housing

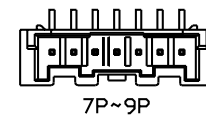
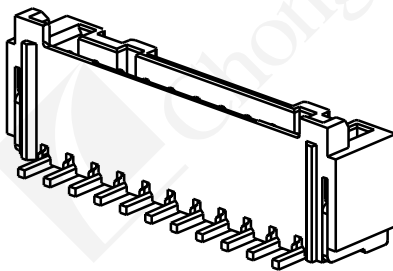

7P~9P

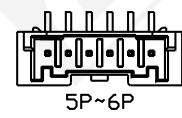

5P~6P

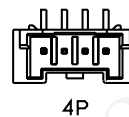

4P

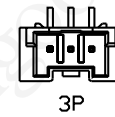

3P

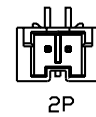

2P

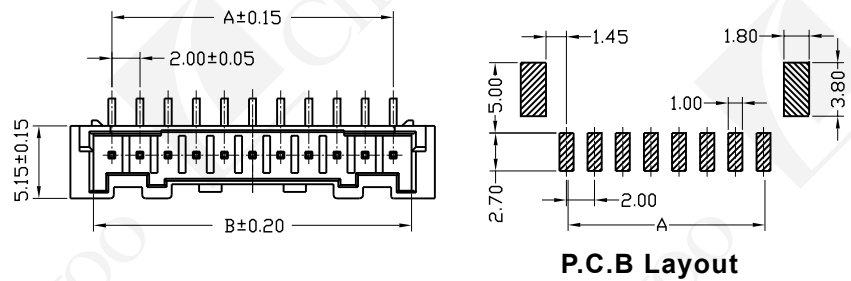

P.C.B Layout

■ Ordering Information & Dimensions

PART No.	A	C	D	PART No.	A	C	D
A2005AWV-2P	2.00	4.60	7.90	A2005AWV-9P	16.00	18.60	21.90
A2005AWV-3P	4.00	6.60	9.90	A2005AWV-10P	18.00	20.60	23.90
A2005AWV-4P	6.00	8.60	11.90	A2005AWV-11P	20.00	22.60	25.90
A2005AWV-5P	8.00	10.60	13.90	A2005AWV-12P	22.00	24.60	27.90
A2005AWV-6P	10.00	12.60	15.90	A2005AWV-13P	24.00	26.60	29.90
A2005AWV-7P	12.00	14.60	17.90	A2005AWV-14P	26.00	28.60	31.90
A2005AWV-8P	14.00	16.60	19.90	A2005AWV-15P	28.00	30.60	33.90

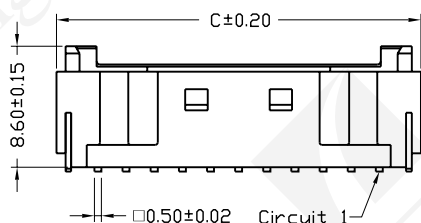



■ A2005AWR (Right Angle Wafer SMT)

Reference Information:

*Material: Pin: Brass / Tin-plated

Solder Tabs: Phosphor Bronze / Tin-plated

Wafer: PA66 (UL94V-0)

*Mates With CG A2005 Series Housing

■ Ordering Information & Dimensions

PART No.	A	C	D	PART No.	A	C	D
A2005AWR-2P	2.00	4.60	7.90	A2005AWR-9P	16.00	18.60	21.90
A2005AWR-3P	4.00	6.60	9.90	A2005AWR-10P	18.00	20.60	23.90
A2005AWR-4P	6.00	8.60	11.90	A2005AWR-11P	20.00	22.60	25.90
A2005AWR-5P	8.00	10.60	13.90	A2005AWR-12P	22.00	24.60	27.90
A2005AWR-6P	10.00	12.60	15.90	A2005AWR-13P	24.00	26.60	29.90
A2005AWR-7P	12.00	14.60	17.90	A2005AWR-14P	26.00	28.60	31.90
A2005AWR-8P	14.00	16.60	19.90	A2005AWR-15P	28.00	30.60	33.90

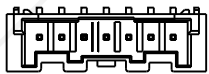
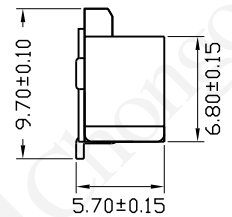
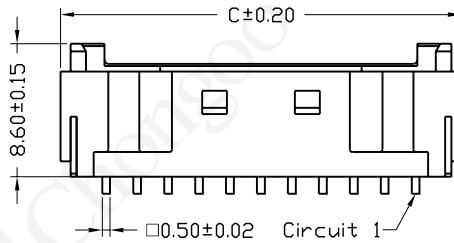
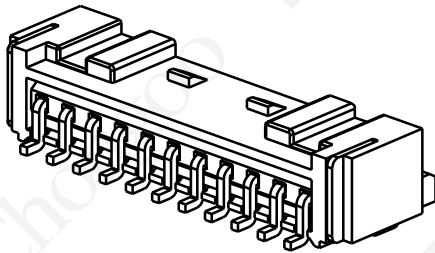

7P~9P

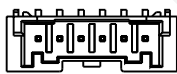

5P~6P

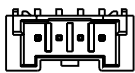

4P

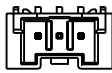

3P



2P

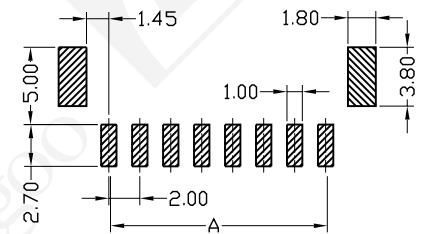
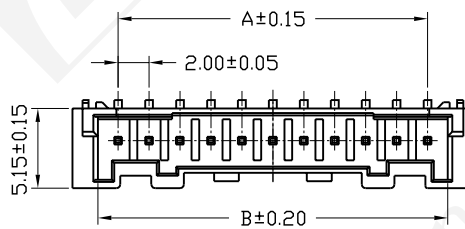

P.C.B Layout

Wire to Board Connector