

■ 技术参数 Technical parameter

1. 间距 Pitch: 1.0mm
2. 额定电流 Current Rating: 0.5A AC/DC.
3. 额定电压 Voltage Rating: 50V AC/DC.
4. 温度范围 Temperature range: -40°C~+85°C
5. 耐压 Withstand Voltage: 500V/min
6. 接触电阻 Contact resistance: $\leq 0.03\Omega$
7. 绝缘电阻 Insulation resistance: $\geq 800M\Omega$

■ 材料 Material

1. 外壳 Housing: PA46/PA6T UL94V-0
2. 锁扣 Loeker: PPS UL94V-0
3. 接触片 Contact: Phosphor bronze, Copper & Tin plating
4. 焊片 Solder tab: Phosphor bronze, Copper & Tin plating

FPC/FFC Connector

■ 卧式(SMT)上触点 Side Entry Top Contact

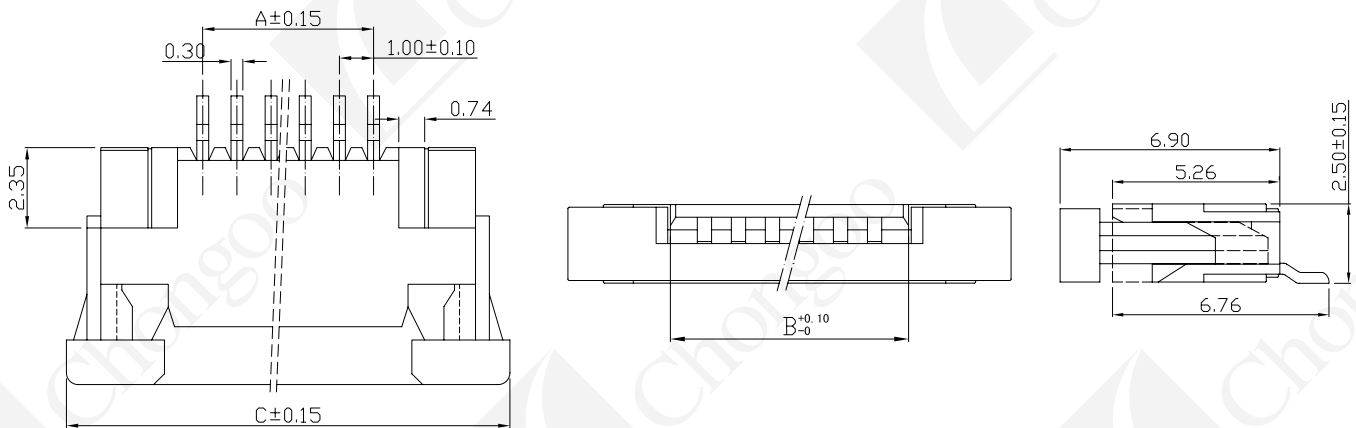

■ 印刷电路板 PC board layout

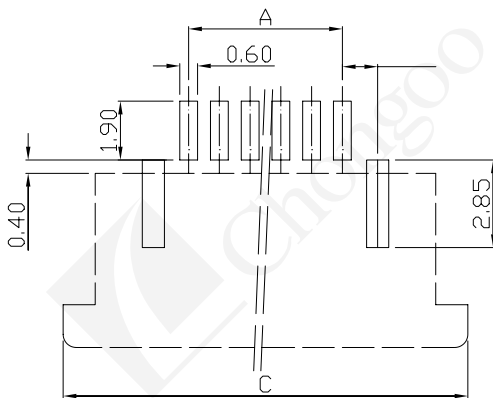

■ 适用FFC/FPC Applicable FFC/FPC

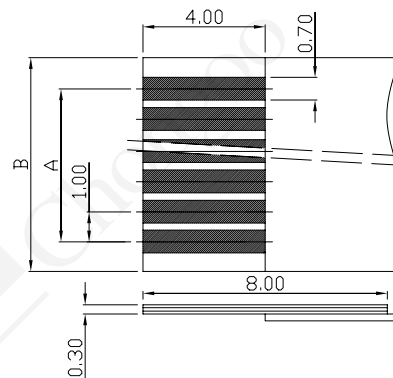

■ 命名与尺寸(上接触)

Ordering Information & Dimensions(Top Contact)

PART No.	A	B	C	PART No.	A	B	C	PART No.	A	B	C
FPC1.0C-4Pt	3.00	5.00	11.10	FPC1.0C-15Pt	14.00	16.00	22.10	FPC1.0C-26Pt	25.00	27.00	33.10
FPC1.0C-5Pt	4.00	6.00	12.10	FPC1.0C-16Pt	15.00	17.00	23.10	FPC1.0C-27Pt	26.00	28.00	34.10
FPC1.0C-6Pt	5.00	7.00	13.10	FPC1.0C-17Pt	16.00	18.00	24.10	FPC1.0C-28Pt	27.00	29.00	35.10
FPC1.0C-7Pt	6.00	8.00	14.10	FPC1.0C-18Pt	17.00	19.00	25.10	FPC1.0C-29Pt	28.00	30.00	36.10
FPC1.0C-8Pt	7.00	9.00	15.10	FPC1.0C-19Pt	18.00	20.00	26.10	FPC1.0C-30Pt	29.00	31.00	37.10
FPC1.0C-9Pt	8.00	10.00	16.10	FPC1.0C-20Pt	19.00	21.00	27.10	FPC1.0C-31Pt	30.00	32.00	38.10
FPC1.0C-10Pt	9.00	11.00	17.10	FPC1.0C-21Pt	20.00	22.00	28.10	FPC1.0C-32Pt	31.00	33.00	39.10
FPC1.0C-11Pt	10.00	12.00	18.10	FPC1.0C-22Pt	21.00	23.00	29.10	FPC1.0C-33Pt	32.00	34.00	40.10
FPC1.0C-12Pt	11.00	13.00	19.10	FPC1.0C-23Pt	22.00	24.00	30.10	FPC1.0C-34Pt	33.00	35.00	41.10
FPC1.0C-13Pt	12.00	14.00	20.10	FPC1.0C-24Pt	23.00	25.00	31.10	FPC1.0C-35Pt	34.00	36.00	42.10
FPC1.0C-14Pt	13.00	15.00	21.10	FPC1.0C-25Pt	24.00	26.00	32.10	FPC1.0C-36Pt	35.00	37.00	43.10