

■ 技术参数 TECHNICAL PARAMETR

1. 间距 Pitch: 1.0mm
2. 额定电流 Current Rating: 0.5A AC/DC.
3. 额定电压 Voltage Rating: 50V AC/DC.
4. 温度范围 Temperature range: -40°C~+85°C
5. 耐压 Withstand Voltage: 500V/min
6. 接触电阻 Contact resistance: $\leq 0.03\Omega$
7. 绝缘电阻 Insulation resistance: $\geq 800M\Omega$
8. 适用印刷电路板厚度 Applicable PC board thickness: 0.8~1.6mm

■ 材料 Material

1. 外壳 Housing: PA46/PA6T UL94V-0
2. 接触片 Contact: Phosphor bronze, Copper & Tin plating

■ 立式 Top Entry Dual Contact

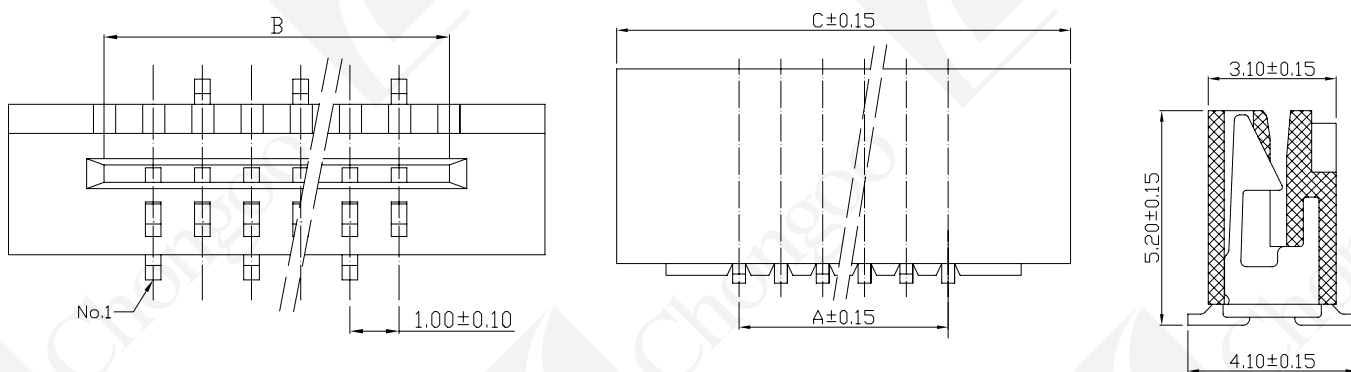

■ 印刷电路板 PC board layout

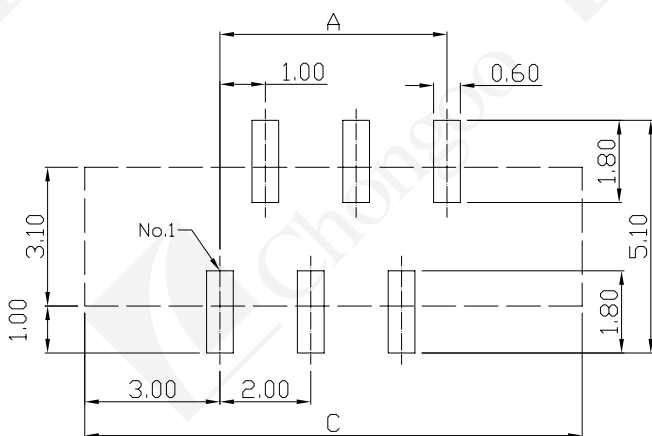

■ 适用FFG/FPC Applicable FFC/FPC

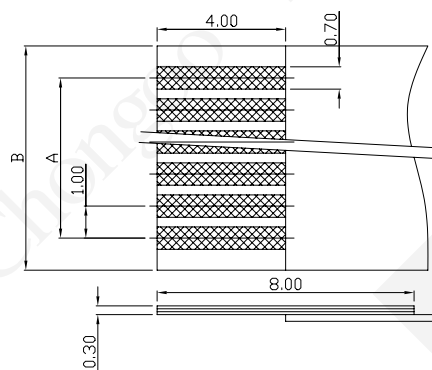

■ 编号与尺寸

Ordering Informftion & Dimensions

PART No.	A	B	C	PART No.	A	B	C	PART No.	A	B	C
FPC1.0G-4P	3.00	5.00	9.00	FPC1.0G-13P	12.00	14.00	18.00	FPC1.0G-22P	21.00	23.00	27.00
FPC1.0G-5P	4.00	6.00	10.00	FPC1.0G-14P	13.00	15.00	19.00	FPC1.0G-23P	22.00	24.00	28.00
FPC1.0G-6P	5.00	7.00	11.00	FPC1.0G-15P	14.00	16.00	20.00	FPC1.0G-24P	23.00	25.00	29.00
FPC1.0G-7P	6.00	8.00	12.00	FPC1.0G-16P	15.00	17.00	21.00	FPC1.0G-25P	24.00	26.00	30.00
FPC1.0G-8P	7.00	9.00	13.00	FPC1.0G-17P	16.00	18.00	22.00	FPC1.0G-26P	25.00	27.00	31.00
FPC1.0G-9P	8.00	10.00	14.00	FPC1.0G-18P	17.00	19.00	23.00	FPC1.0G-27P	26.00	28.00	32.00
FPC1.0G-10P	9.00	11.00	15.00	FPC1.0G-19P	18.00	20.00	24.00	FPC1.0G-28P	27.00	29.00	33.00
FPC1.0G-11P	10.00	12.00	16.00	FPC1.0G-20P	19.00	21.00	25.00	FPC1.0G-29P	28.00	30.00	34.00
FPC1.0G-12P	11.00	13.00	17.00	FPC1.0G-21P	20.00	22.00	26.00	FPC1.0G-30P	29.00	31.00	35.00